



ADVANTAGE TURO Grit Pump

EGGER "TURO Grit" pump's has many features which make it better than the competitor's 60-year old cupped impeller pump design:

- Fact Sheet 2016-001 Fully Recessed Impeller
- Fact Sheet 2016-002 Curved Impeller Vanes
- Fact Sheet 2016-003 Centered Casing
- Fact Sheet 2016-004 Lower Tip Speeds
- Fact Sheet 2016-005 Rear Pump-Out Vanes
- Fact Sheet 2016-006 Self Venting
- Fact Sheet 2016-007 Jacking Bolts
- Fact Sheet 2016-008 Axial Spiral Casing
- Fact Sheet 2016-009 Rear Pull-Out Assembly
- Fact Sheet 2016-010 Trimmable Impeller
- Fact Sheet 2016-011 Shaped Impeller Nut
- Fact Sheet 2016-012 Energy Efficiency

ADVANTAGE TURO:

Turo's design advantage is not one feature, but the sum of many parts!



FACT Sheet: 2016-001

ADVANTAGE TURO: Fully Recessed Impeller

The TURO vortex impeller is fully recessed into the rear casing and is behind the fluid flow.



As the impeller spins a vortex is created within the pump and this vortex extends into the suction nozzle. Turo's fully recessed design minimizes contact with the fluid to approximately 15 percent of the abrasive particles being pumped.

ADVANTAGE TURO: 85% of the pumped fluid never comes in contact with the impeller

ADVANTAGE TURO: Less contact with the pumped fluid = Less wear = Longer Life!



FACT Sheet: 2016-002

ADVANTAGE TURO: Curved Impeller Vanes

EGGER TURO's Impeller is curved for reduced wear and achieve higher efficiencies



Typical straight Vane Impeller



Turo's Curved Vane Impeller

- Straight vane impeller - flow leaves the impeller at a greater absolute velocity, resulting in a sand blasting effect onto the casing causing wear.
- EGGER's curved impeller vanes reduces the absolute velocities of flow particles, while also producing greater radial flow velocities.

ADVANTAGE TURO: Reduced Absolute Velocity = Less Impact = Reduced Wear

ADVANTAGE TURO: Greater Radial Velocity = More Pressure Generated = Higher Efficiency



FACT Sheet: 2016-003

ADVANTAGE TURO: Centered Casing

EGGER TURO's Centered Casing places the impeller in the middle of the casing:

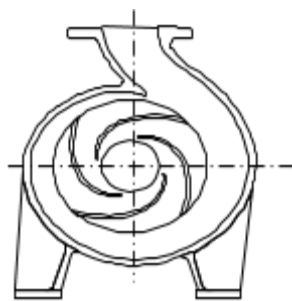

Competitor's Offset Casing

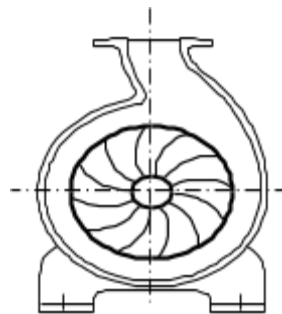

EGGER's Centered Casing

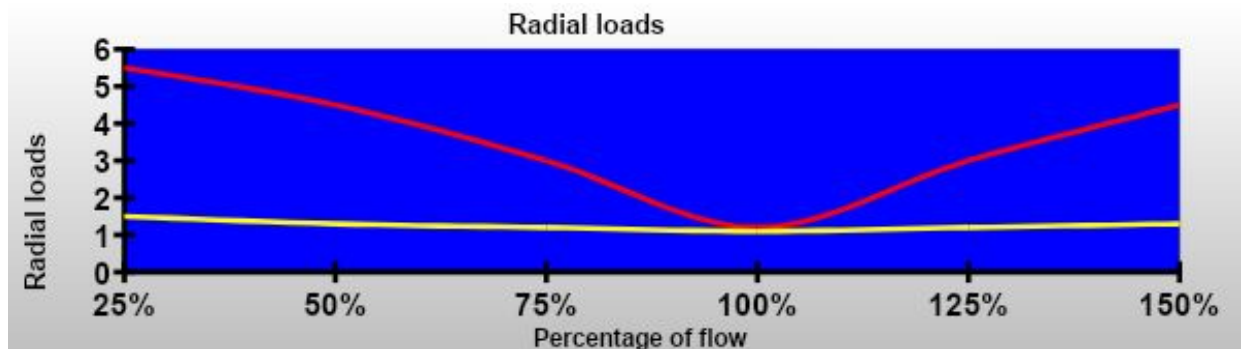

Offset Casing (red line) has 4 times the radial loads at 25% & 150% flows versus EGGER's Centered Casing (yellow line) with radial loads that are low and uniform over the entire flow range.

Also, our centered casing design allows solids to pass all around the impeller

ADVANTAGE TURO: Reduced Radial Loads = Smooth Flow = Longer Life!



FACT Sheet: 2016-004

ADVANTAGE TURO: Lower Tip Speeds

Pumps designed 60 years ago in an era when engineers felt that a thicker, heavier pump meant longer life. The 0.75 to 1.0 inch thick impeller vanes and leading edge greatly reduced the available “bucket” volume or the amount of work the pump could do in one revolution. The reduced bucket volume required the use of larger diameter impellers to meet the required flows in a given pump size.

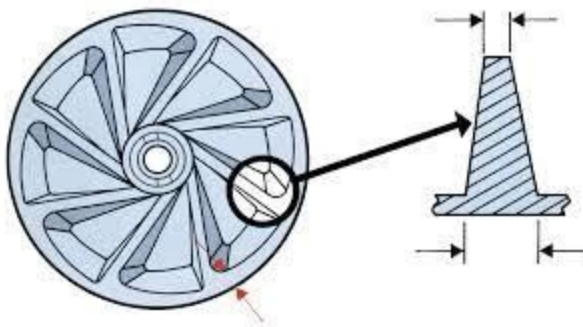

Cupped Impeller



TURO 8-Vane

Our TURO recessed impeller weighs less, uses thinner vanes and does not have a leading edge which allows EGGER to use a smaller 8.32 inch versus a 15.875 inch impeller diameter.

Although the cupped impeller pump runs at a slower 1200 rpm where the TURO runs at 1750 rpm. This argument falls apart when you consider the “tip speed” for each realizing our smaller diameter impeller at 1750 rpm has a tip speed of 63.5 versus theirs at 83.1 feet/second. (See below).

Manufacturer	Flow (gpm)	tdh	Model	Size	Speed	BHP	% Eff.	Imp. dia.	Tip Speed ft/sec.	* Yearly energy consumption
Cupped Impeller	500	70	P10C-D56	4"x4"	1200	26.00	34.0%	15.875	83.1	\$ 13,592.72
EGGER TURO	500	70	T61-80 LB3B	4"x3"	1750	16.30	54.2%	8.320	63.5	\$ 8,521.59

* Yearly energy consumption based on 8 cents per kwh and 24 hours/day operation

ADVANTAGE TURO: Lower Tip Speeds = Less Wear



FACT Sheet: 2016-005

ADVANTAGE TURO: Rear Pump-Out Vanes

EGGER TURO's Recessed Impeller Pump uses "Rear Pump-Out" vanes which are cast into the backside of the impeller.



Rear Pump-Out Vanes

Typical wastewater applications such as raw sewage, sludge, scum, and grit contain many types of solids including sand, grit, rags, and hair.

Problem's with the 60 yr. old design which does not use rear pump-out vanes:

- NO pump-out vanes has the potential to build-up of solids behind the impeller and in front of the mechanical seal causing the seal faces to run dry and fail.
- No pump-out vanes allow abrasive particles behind the impeller causing wear, requiring an additional wear plate behind the impeller.

ADVANTAGE TURO: EGGER's pump-out vanes will flush the area clean and not allow solids to accumulate in front of the mechanical seal = longer seal life.

ADVANTAGE TURO: EGGER's pump-out vanes will prevent abrasive particles from causing wear behind the impeller = eliminates the need for a wear plate behind the impeller.



FACT Sheet: 2016-006

ADVANTAGE TURO: Self Venting Centerline Discharge

EGGER TURO's Recessed Impeller Vortex pump uses our unique "Centerline Discharge".

Air becomes trapped

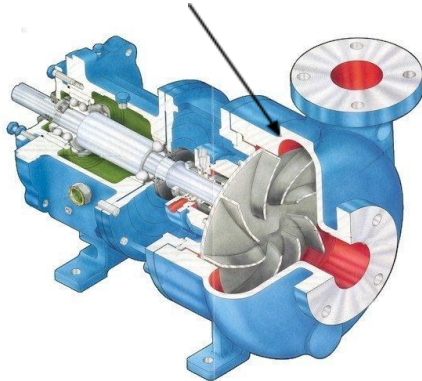

Tangential Discharge

Self Venting

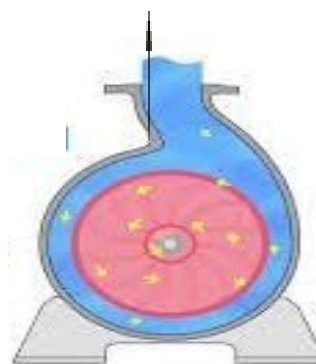

EGGER's Centerline Discharge

Sludge pumps typically run 4-hours per day which means they sit idle for approximately 20 hours and longer on weekends. As they sit, the sludge in the pump will begin to degas releasing air bubbles which will rise to the highest point in the pump.

- ✓ A tangential pump may become air bound and require the use of an air release valve resulting in an additional maintenance item.
- ✓ EGGER's TURO pump allows the air to escape through the discharge pipe.

ADVANTAGE TURO: Pump cannot become air bound



FACT Sheet: 2016-007

ADVANTAGE TURO: Jacking Bolts

TURO's maintenance friendly design includes jacking bolts.



- Maintenance Friendly: maintenance personnel love this feature when they have to work on a 15 year old pump!

ADVANTAGE TURO: Easy removal of the back pull-out unit from the pump volute casing.



FACT Sheet: 2016-008

ADVANTAGE TURO: Axial Spiral Casing

TURO's Volute casing is cast with an "Axial Spiral" shape:

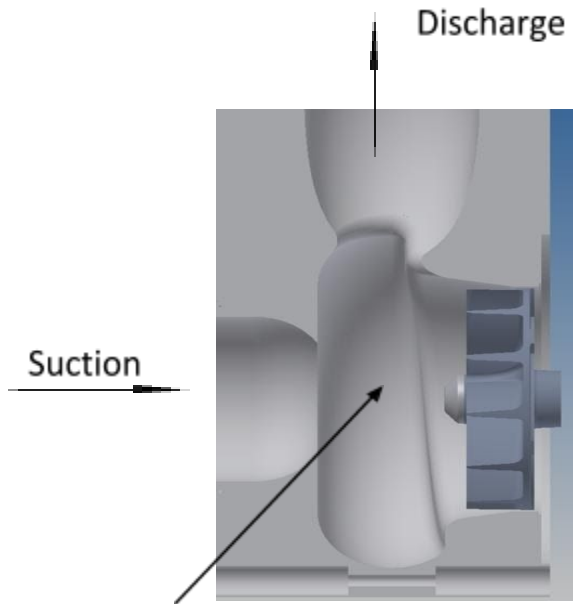

Axial Spiral directs flow away from the impeller

The axial spiral casing directs fluid flow away from the impeller helping to reduce recirculation resulting in higher efficiencies.

Turo's fully recessed impeller and axial spiral casing were designed so that only 15% of the pumped flow contacts the impeller.

ADVANTAGE TURO:

Axial Spiral provides an optimal flow path = reduced recirculation = increased efficiency.

Axial Spiral re-directs 85% of the fluid away from impeller = abrasive particles never touch the impeller = greatly reduces wear.



FACT Sheet: 2016-009

ADVANTAGE TURO: Rear Pull-Out Assembly

EGGER TURO Series of pumps utilize a foot on the casing which allows for Rear “Pull-Out” of the rotating assembly.

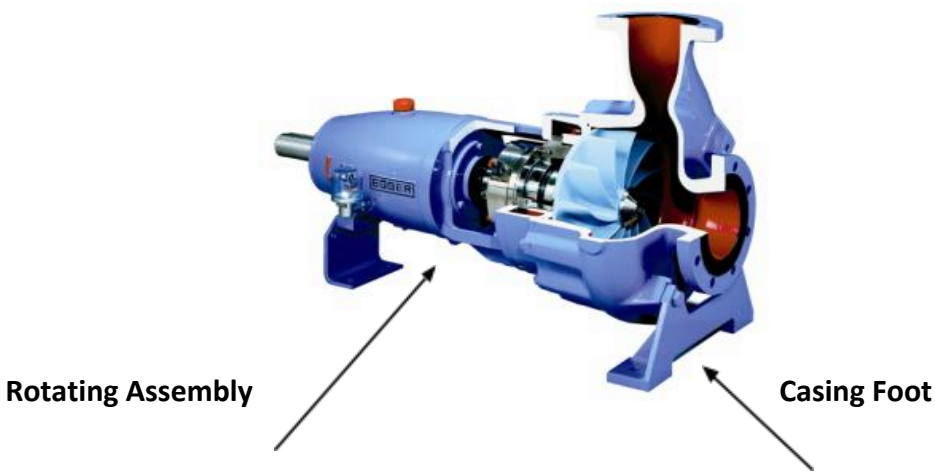

ADVANTAGE TURO: Easy repairs without the need to disturb the suction and discharge piping or removal of the entire pump.



FACT Sheet: 2016-010

ADVANTAGE TURO: Trimmable Impeller

The TURO vortex impeller is trimmable and in most cases runs at synchronous motor speeds.



Impeller is fully recessed behind the fluid flow

- **Vortex Impeller** – Turo’s impeller creates a true vortex which extends into the suction nozzle helping to minimize recirculation in the casing.
- **Fully Recessed Design** – Turo’s impeller is fully recessed into the rear of the casing outside of the fluid flow and does not require a rim on the perimeter of the impeller.
- **Axial Spiral Casing** – Turo’s axial spiral casing prevents 85% of solid particles from flowing through the impeller eliminating the need for a rim surrounding the impeller vane tips.



Full Size Impeller

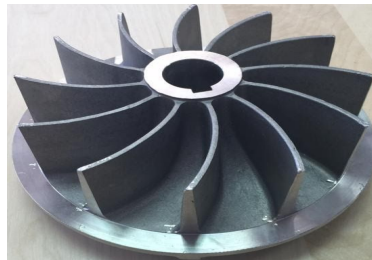

Trimmed Impeller

ADVANTAGE TURO: Turo’s rimless impeller design gives EGGER the ability to trim the impeller to meet your exact flow and pressures while running at 4, 6, or 8 pole synchronous speeds eliminating the need for gear reducers or V-belt drives, a more efficient drive system.



ADVANTAGE TURO: Shaped Impeller Nut

EGGER TURO's fully recessed vortex impeller uses a shaped impeller nut.

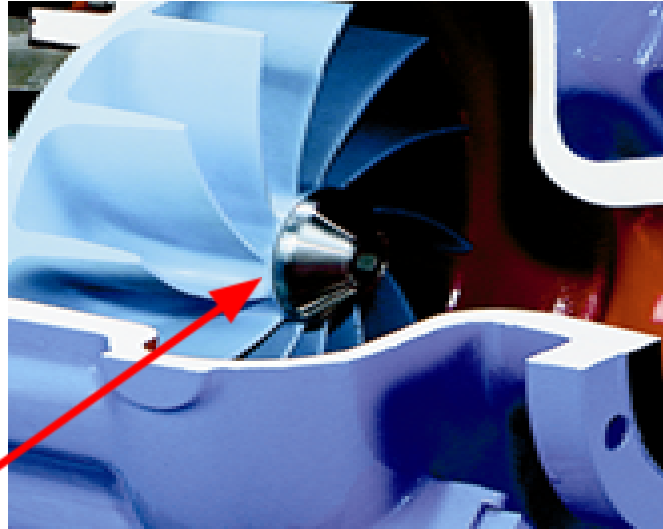

Shaped Impeller Nut

Typical wastewater applications such as raw sewage, sludge, scum, and grit contain many types of solids including sand, grit, rags, and hair which could easily clog a pump.

ADVANTAGE TURO: Turo's shaped impeller nut helps direct debris away from the eye of the impeller so that it cannot clog!



